

# SPW501

## thermally broken screening and door system

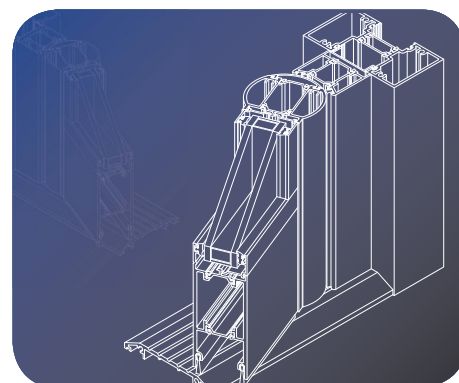

### Scope

The SPW501 system has been designed to provide a high performance commercial door and framing solution capable of being manufactured in single, double, and emergency door types and utilising low thresholds and a variety of options such as radius anti-finger trap stiles. It is a thermally broken polyamide framing system, capable of accepting glazing up to 28mm thick depending on weight.

### Materials

- All aluminium sections are extruded using Aluminium Alloy 6060 or 6063 T6 to BS EN 755 part 9 2008.
- Polyamide thermal barriers are manufactured in accordance with PA66 GF25.
- Gaskets are manufactured in accordance with BS3734.

### Finishes

SPW501 framing sections are available typically in 3 finishes:

- Polyester Powder Coating to BS EN 12206: 2004 Part 1 - painted in house in single or dual colour and surface finish at 40 microns standard, or enhanced to 60 microns for marine environments, in accordance with ISO9001, ISO14001 and ISO18001.
- Anodised and Anolok finishes are to BS3897: 1991 to a minimum of 25 microns (AA25), supplied in either satin or polished finish in a limited range of colours.
- Mill finish.

### Construction

SPW501 is constructed with square cut components, mechanically jointed using self tapping screws into special cleats, and torsion bars are used for compressive strength. A proprietary sealant is used on all metal joints in line with good practice.

Automation solutions are also available.

# SPW501

## thermally broken screening and door system

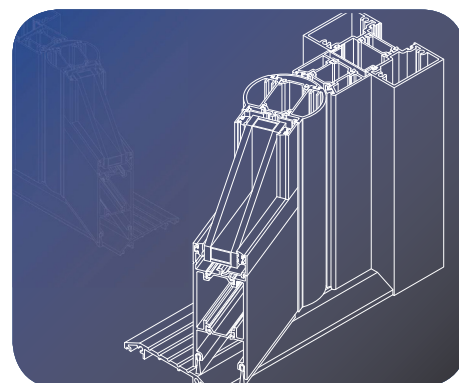

### Technical Data

#### Weather rating

Differing door configurations produce different ratings. Please consult our technical department.

#### Typical\* sizes

	Width (mm)	Height (mm)
Single Door	1150	2490
Double Door	2390	2490

\*For guidance only - when exceeded please consult our technical department.

#### Glazing

Thickness	28mm
-----------	------

#### Security

PAS24, for both single and double doors, please refer to the technical manual for security hardware requirements.

#### Average U values (door)

	Single	Double
Fully glazed	2.12W/m2K	2.10W/m2K
With mid rail	2.22W/m2K	2.21W/m2K

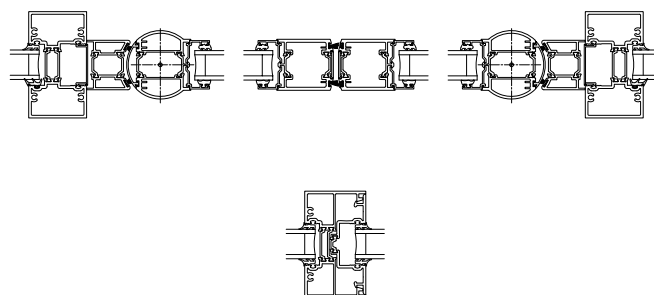

### Environmental

SPW501 when used on projects involved in a BREEAM assessment, or within the Code for a Sustainable Built Environment and the Code for Sustainable Homes (which therefore involves the Green Guide to specification) can offer significant benefits. For project specific assistance, please contact our specification team.

#### Specification.

**Please contact our team for advice on product suitability, calculations and NBS or bespoke specifications.**

All data in this specification sheet is courtesy of Senior Architectural Systems. Soundcraft Doors and Windows works in partnership with Senior Architectural Systems.

Soundcraft, Orchard Building, Hewitts Road, Orpington, Kent. BR6 7QL

T: 01959 533778 E: sales@soundcraft-doors.co.uk [www.soundcraft-doors.co.uk](http://www.soundcraft-doors.co.uk)

Soundcraft is a trading name of JKR Services Ltd. Registered Office: Chandler & Georges, 75 Westow Hill, London SE19 1TX. Registered No: 2201723

