

Hybrid Series 2 casement window system

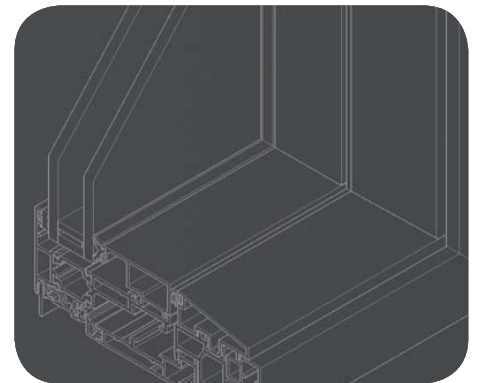

Scope

Hybrid Series 2 casement windows feature slimmer sightlines for increased aesthetics and have been designed to exceed current and meet future building regulations, with impressive U Values and thermal performances. Hybrid is a high insulation timber/aluminium composite system manufactured in the UK, complete with a selection of window, curtain walling and door options. It combines the long life and low maintenance of aluminium externally with the high insulation, environmentally focused benefits of responsibly sourced engineered timber internally. Hybrid Series 2 casement windows are capable of accepting glazing up to 44mm thick depending on weight.

Materials

- All aluminium sections are extruded using Aluminium Alloy 6060 or 6063 T6 to BS EN 755 part 9 2008 or BS En 12020-2.
- Polyamide thermal barriers are manufactured in accordance with PA66 GF25.
- Gaskets are manufactured in accordance with BS3734.
- Timber profiles are certified by MPA Stuttgart with quality class BS1100, laminated according to DIN1502 using weather proof and heat proof melamine glue; moisture content 12% +/- 2%; only lamellas without fault are laminated. Finger joints in outer layer min 500mm centres. PEFC /04-32-0042 certified. Timber profiles are matt lacquered 150- 300 microns wet film thickness.

Finishes

Hybrid Series 2 Casement window sections are available typically in three finishes:

- Polyester Powder Coating to BS EN 12206:2004 Part 1 – painted in house. Surface finish at 40 microns standard, or enhanced to 60 microns for marine environments, in accordance with ISO9001, ISO14001 and ISO18001.
- Anodised finishes are to BS3897: 1991 to a minimum of 25 microns (AA25), supplied in either satin or polished finish in a limited range of colours.
- Clear lacquered or painted timber.

Construction

Hybrid Series 2 casement windows are constructed using mitre corners, joined with crimped alignment chevrons which assist in clean accurate mitres. Integral transoms and mullions are scribed around the outer frames and fixed with either screw ports or shear blocks. A proprietary sealant is used on all metal joints in line with good practice, and all permanently exposed cut timber faces are sealed in accordance with the manufacturers' recommendations. Opening window frames are designed to be inserted directly into the outer frames using friction stays, and glazed internally.

Hybrid Series 2 casement window system

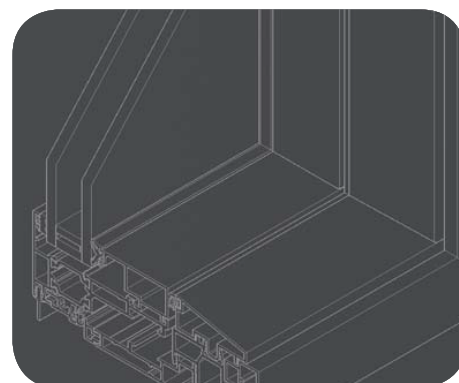

Technical Data

Typical* sizes

Top Hung Open Out	1600mm (w) x 1600mm (h)
Side Hung Open Out	1000mm (w) x 1600mm (h)

*For guidance only – when exceeded please consult our technical department

Weather Rating

BS6375 Part 1: 2009

Air Permeability	600 Pa
Water Tightness	600 Pa
Wind Resistance	2400 Pa

Security

Tested to PAS24:2012, BS6375 Part 2 & 3

Glazing

Thickness	28mm - 44mm
-----------	-------------

Average U values

Residential CEN standard	1230 x 1480
28mm Double Glazed Unit	1.40 W/m ² K
44mm Triple Glazed Unit	1.04 W/m ² K
Commercial CEN standard	1230 x 1480
28mm Double Glazed Unit	1.27 W/m ² K
44mm Triple Glazed Unit	0.90 W/m ² K

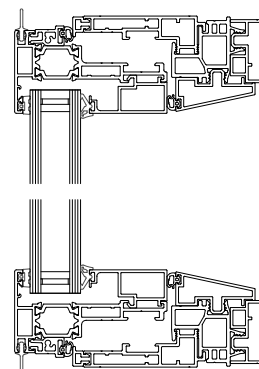

Environmental

Hybrid casement windows when used on projects involved in a BREEAM assessment, or within the Code for a Sustainable Built Environment and the Code for Sustainable Homes (which therefore involves the Green Guide to specification) can offer significant benefits. For project specific assistance, please contact our specification team.

Specification.

Please contact our team for advice on product suitability, calculations and NBS or bespoke specifications.

All data in this specification sheet is courtesy of Senior Architectural Systems. Soundcraft Doors and Windows works in partnership with Senior Architectural Systems.

Soundcraft, Orchard Building, Hewitts Road, Orpington, Kent. BR6 7QL
T: 01959 533778 E: sales@soundcraft-doors.co.uk www.soundcraft-doors.co.uk

Soundcraft is a trading name of JKR Services Ltd. Registered Office: Chandler & Georges, 75 Westow Hill, London SE19 1TX. Registered No: 2201723

