

PURe® FOLD single/double door system

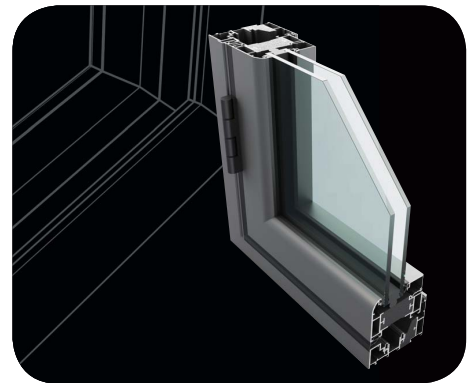

Scope

The PURe® FOLD single or double door has been designed to meet current and future building regulation, with impressive U values and thermal performances. PURe® is an evolved generation of aluminium door systems manufactured in the UK. They combine the long life and low maintenance of powder coated aluminium externally with a patent pending high insulation PUR foam thermal barrier. PURe® single and double doors are capable of accepting glazing up to 48mm thick depending on weight.

Materials

- All aluminium sections are extruded using Aluminium Alloy 6060 or 6063 T6 to BS EN 755 part 9 2008 or BS EN 12020-2.
- Polyamide thermal barriers are manufactured in accordance with PA66 GF25.
- Gaskets are manufactured in accordance with BS3734.

Finishes

PURe® single or double door sections are available typically in two finishes:

- Polyester Powder Coating to BS EN 12206:2004 Part 1 – painted in house. Surface finish at 40 microns standard, or enhanced to 60 microns for marine environments, in accordance with ISO 9001, ISO 14001 and ISO 18001.
- Anodised finishes are to BS3897: 1991 to a minimum of 25 microns (AA25), supplied in either satin or polished finish in a limited range of colours.

Construction

PURe® is constructed using mitred corners, joined with crimped or mechanical cleats; alignment chevrons assist in clean, accurate mitres.

A proprietary sealant is used on all metal joints in line with good practice.

PURe[®] FOLD single/double door system



Technical Data

Weather rating

Tested to BS6375-1, BS6375-2 and BS6375-3

Patent Pending Number

1500459.1

Typical* sizes

Max Door Leaf Width	1000mm
Max Door Leaf Height	2616mm
Max Single Door Width	1130mm
Max Double Door Width	2162mm
Max Outerframe Height	2700mm
Max Weight Per Door Leaf	100Kg

*For guidance only – when exceeded please consult our technical department

Glazing

Thickness	28mm - 48mm
-----------	-------------

For thicker options please consult our technical department

Average U values

CEN standard - Standard	1230 x 2180mm
28mm Double Glazed Unit	1.45 W/m ² K
48mm Triple Glazed Unit	1.04 W/m ² K
CEN standard - Thermally Enhanced	1230 x 2180mm
28mm Double Glazed Unit	1.43 W/m ² K
48mm Triple Glazed Unit	1.02 W/m ² K
Double Door. CEN standard - Standard	2000 x 2180mm
28mm Double Glazed Unit	1.40 W/m ² K
48mm Triple Glazed Unit	0.99 W/m ² K
Double Door. CEN standard - Thermally Enhanced	2000 x 2180mm
28mm Double Glazed Unit	1.38 W/m ² K
48mm Triple Glazed Unit	0.97 W/m ² K

Security

Security tested to PAS24: 2012, security hardware required. Q-Mark fully certified.

Environmental

PURe[®], when used on projects involved in a BREEAM assessment, or within the Code for a Sustainable Built Environment and the Code for Sustainable Homes (which therefore involves the Green Guide to specification) can offer significant benefits. For project specific assistance, please contact our specification team.

Specification.

Please contact our team for advice on product suitability, calculations and NBS or bespoke specifications.

All data in this specification sheet is courtesy of Senior Architectural Systems. Soundcraft Doors and Windows works in partnership with Senior Architectural Systems.

Soundcraft, Orchard Building, Hewitts Road, Orpington, Kent. BR6 7QL

T: 01959 533778 E: sales@soundcraft-doors.co.uk www.soundcraft-doors.co.uk

Soundcraft is a trading name of JKR Services Ltd. Registered Office: Chandler & Georges, 75 Westow Hill, London SE19 1TX. Registered No: 2201723

