

SPW300 pivot window system

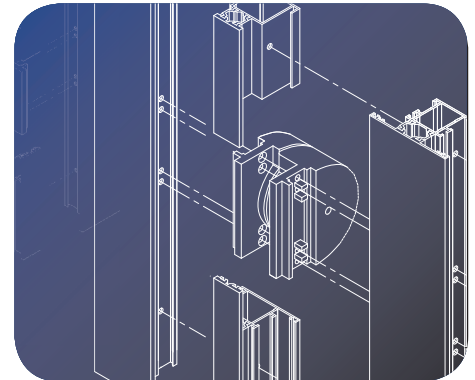

Scope

The SPW300 pivot window has been designed to meet current building regulations. It is a 51mm thermally broken polyamide window system that achieves good thermal performance. It is capable of accepting a variety of glazing.

Materials

- All aluminium sections are extruded using Aluminium Alloy 6060 or 6063 T6 to BS EN 755 part 9 2008.
- Polyamide thermal barriers are manufactured in accordance with PA66 GF25.
- Gaskets are manufactured in accordance with BS3734.

Finishes

SPW300 pivot windows sections are available typically in 3 finishes:

- Polyester Powder Coating to BS EN 12206: 2004 Part 1 - painted in house in single or dual colour and surface finish at 40 microns standard, or enhanced to 60 microns for marine environments, in accordance with ISO9001, ISO14001 and ISO18001.
- Anodised and Anolok finishes are to BS3897: 1991 to a minimum of 25 microns (AA25), supplied in either satin or polished finish in a limited range of colours.
- Mill finish.

Construction

SPW300 is constructed using mitred corners, joined with crimped or mechanical cleats; alignment chevrons assist in clean, accurate mitres. Integral transoms and mullions are scribed around the outer frames and fixed with either screw ports or shear blocks. A proprietary sealant is used on all metal joints in line with good practice. Opening window frames are designed to be inserted into outer frames using specialist pivots.

SPW300 pivot window system

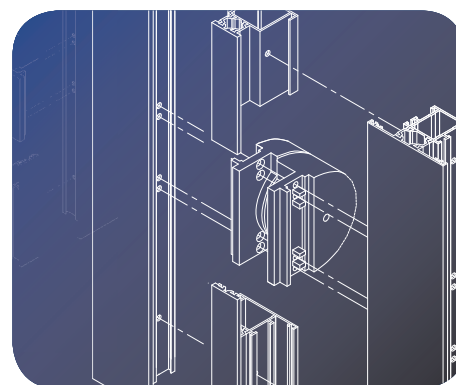

Technical Data

Typical* sizes - Maximum sizes

Horizontal Pivot	1500mm (w) x 1500mm (h)
Vertical Pivot	1000mm (w) x 1500mm (h)

Typical* sizes - Minimum sizes

Horizontal Pivot	500mm (w) x 500mm (h)
Vertical Pivot	500mm (w) x 500mm (h)

*For guidance only – when exceeded please consult our technical department

Weather Rating

BS6375 part 1

Air Permeability	600 Pa
Water Tightness	600 Pa
Wind Resistance	2000 Pa

Glazing

Thickness	4mm - 28mm
-----------	------------

Average U values

	1200 x 1200	1500 x 1500
Vent	2.18W/m ² K	1.98W/m ² K
Fixed	1.65W/m ² K	1.54W/m ² K

Security

Tested to BS7950, security hardware required.

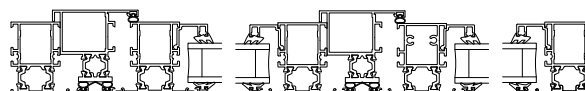

Environmental

SPW300 when used on projects involved in a BREEAM assessment, or within the Code for a Sustainable Built Environment and the Code for Sustainable Homes (which therefore involves the Green Guide to specification) can offer significant benefits. For project specific assistance, please contact our specification team.

Specification.

Please contact our team for advice on product suitability, calculations and NBS or bespoke specifications.

All data in this specification sheet is courtesy of Senior Architectural Systems. Soundcraft Doors and Windows works in partnership with Senior Architectural Systems.

Soundcraft, Orchard Building, Hewitts Road, Orpington, Kent. BR6 7QL
T: 01959 533778 E: sales@soundcraft-doors.co.uk www.soundcraft-doors.co.uk

Soundcraft is a trading name of JKR Services Ltd. Registered Office: Chandler & Georges, 75 Westow Hill, London SE19 1TX. Registered No: 2201723

