

SD/SFG ground floor system

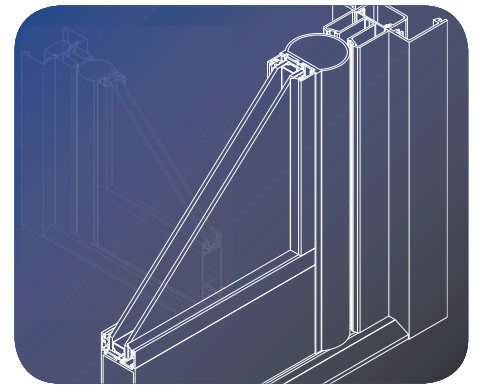

Scope

The SD/SFG system has been designed to provide a high performance commercial door and framing solution capable of being manufactured in single, double, and emergency door types and utilising low thresholds and a variety of options such as radius anti-finger trap stiles. It is capable of accepting glazing from 6mm to 24mm thick depending on weight. Specific profiles can be incorporated offering design flexibility.

Materials

- All aluminium sections are extruded using Aluminium Alloy 6060 or 6063 T6 to BS EN 755 part 9 2008.
- Polyamide thermal barriers are manufactured in accordance with PA66 GF25.
- Gaskets are manufactured in accordance with BS3734.

Finishes

SD/SFG framing sections are available typically in 3 finishes:

- Polyester Powder Coating to BS EN 12206: 2004 Part 1 - painted in house in single or dual colour and surface finish at 40 microns standard, or enhanced to 60 microns for marine environments, in accordance with ISO9001, ISO14001 and ISO18001.
- Anodised and Anolok finishes are to BS3897: 1991 to a minimum of 25 microns (AA25), supplied in either satin or polished finish in a limited range of colours.
- Mill finish.

Construction

SD/SFG is constructed with square cut components, mechanically jointed using self tapping screws into special cleats, and torsion bars are used for compressive strength. A proprietary sealant is used on all metal joints in line with good practice.

Automation solutions are also available.

SD/SFG ground floor system

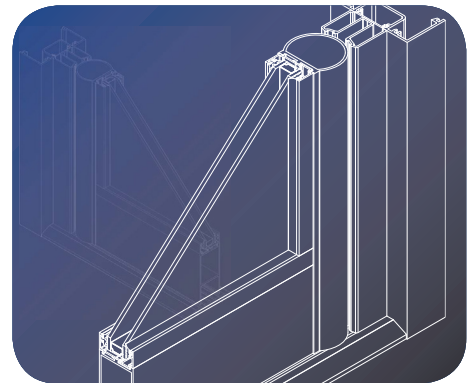

Technical Data

Weather rating

Differing door configurations produce different ratings. Please consult our technical department.

Typical* sizes

	Width (mm)	Height (mm)
Single Door	1150	2300
Double Door	2300	2300

*For guidance only - when exceeded please consult our technical department.

Glazing

Thickness	24mm
-----------	------

Security

PAS24, security hardware required (single door), security hardware required

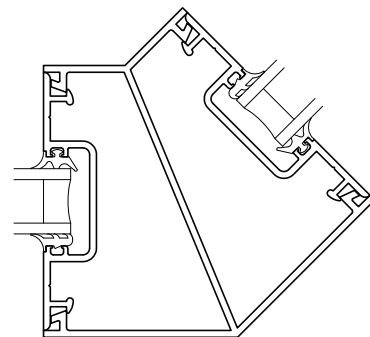
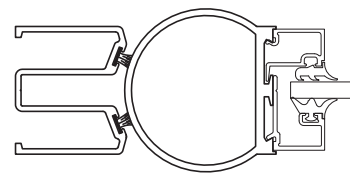

Environmental

SD/SFG when used on projects involved in a BREEAM assessment, or within the Code for a Sustainable Built Environment and the Code for Sustainable Homes (which therefore involves the Green Guide to specification) can offer significant benefits. For project specific assistance, please contact our specification team.

Specification.

Please contact our team for advice on product suitability, calculations and NBS or bespoke specifications.

All data in this specification sheet is courtesy of Senior Architectural Systems. Soundcraft Doors and Windows works in partnership with Senior Architectural Systems.

Soundcraft, Orchard Building, Hewitts Road, Orpington, Kent. BR6 7QL
T: 01959 533778 E: sales@soundcraft-doors.co.uk www.soundcraft-doors.co.uk

Soundcraft is a trading name of JKR Services Ltd. Registered Office: Chandler & Georges, 75 Westow Hill, London SE19 1TX. Registered No: 2201723

