

Hybrid series 1 composite tilt/turn window system

Product Data Sheet
Edition 02.2013
Identification no. 000007
Version no. 01

Page 1 of 2

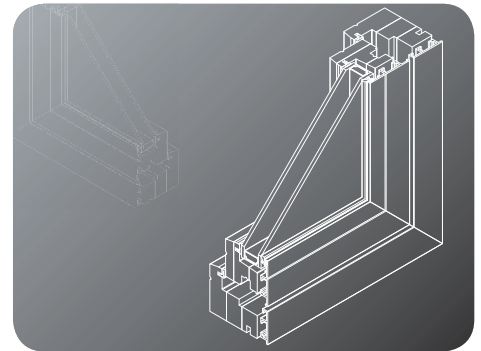

Scope

Hybrid series 1 tilt and turn windows have been designed to meet current and future building regulations, with impressive U values and thermal performances. Hybrid is a high insulation timber/aluminium composite system manufactured in the UK, complete with a selection of window, curtain walling and door options. It combines the long life and low maintenance of aluminium externally with the high insulation, environmentally focused benefits of responsibly sourced engineered timber internally. Hybrid series 1 tilt and turn windows are capable of accepting glazing up to 28mm thick depending on weight.

Materials

- All aluminium sections are extruded using Aluminium Alloy 6060 or 6063 T6 to BS EN 755 part 9 2008.
- Polyamide thermal barriers are manufactured in accordance with PA66 GF25.
- Gaskets are manufactured in accordance with BS3734.
- Timber profiles are certified by MPA Stuttgart with quality class BS1100, laminated according to DIN1502 using weather proof and heat proof melamine glue; humidity 12% +/-2%; only lamellas without fault are laminated. Finger joints in outer layer min 500mm centres. PEFC /04-32-0042 certified. Timber profiles are matt lacquered 150-300 microns wet film thickness.

Finishes

Hybrid series 1 tilt and turn window sections are available typically in 4 finishes.

- Polyester Powder Coating to BS EN 12206: 2004 Part 1 - painted in house. Surface finish at 40 microns standard, or enhanced to 60 microns for marine environments, in accordance with ISO9001, ISO14001 and ISO18001.
- Anodised and Anolok finishes are to BS3897: 1991 to a minimum of 25 microns (AA25), supplied in either satin or polished finish in a limited range of colours.
- Mill finish.
- Clear lacquered or painted timber

Construction

Hybrid is constructed using mitred and mechanically crimped corners, with support chevrons and cleats, and patented dovetail keys. Integral transoms and mullions are scribed around the outer frames and fixed with either screw ports or shear blocks. A proprietary sealant is used on all metal joints in line with good practice. Timber mainframe sections are mitre jointed using a unique closed joint system. All cut faces are treated with the proprietary sealant, and all permanently exposed cut timber faces are sealed in accordance with the manufacturers recommendations. Transoms and mullions are installed by scribing the end then fixing to the outer frame. Opening window frames are designed to be inserted directly into the outer frames using tilt and turn mechanisms.

Soundcraft, Orchard Building, Hewitts Road, Chelsfield, Orpington, Kent, BR6 7QL

T: 01959 533778 F: 01959 532544 E: sales@soundcraft-doors.co.uk www.soundcraft-doors.co.uk

Soundcraft is a trading name of JKR Services Ltd. Registered Office: Imperial House, North Street, Bromley, Kent BR1 1SD. Registered No: 2201723



SOUNDCRAFT
DOORS & WINDOWS

Hybrid series 1 composite tilt/turn window system

Environmental

Senior Architectural Systems is fully compliant with BS EN ISO19001, BS EN ISO 14001 and OHSAS 18001 Standards. Hybrid when used on projects involved in a BREEAM assessment, or within the Code for a Sustainable Built Environment and the Code for Sustainable Homes (which therefore involves the Green Guide to specification) can offer significant benefits. For project specific assistance, please contact our specification team.

Weather Rating

BS6375 Part 1

Air Permeability	600 Pa
Water Tightness	600 Pa
Wind Resistance	2400 Pa

Typical* sizes

	Width (mm)		Height (mm)
Tilt and Turn	1200	x	1200

*For guidance only - when exceeded please consult our technical department.

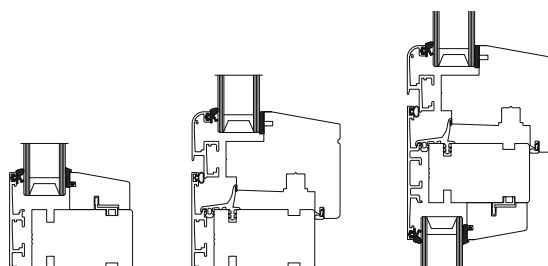

Glazing

Thickness	28mm
-----------	------

Average U values

	1200 x 1200	1500 x 1500
Vent	1.31W/m2K	1.29W/m2K
Fixed	1.31W/m2K	1.29W/m2K

Security

Tested to BS7950, security hardware required

All data in this specification sheet is courtesy of Senior Architectural Systems. Soundcraft Doors and Windows works in partnership with Senior Architectural Systems.

Soundcraft, Orchard Building, Hewitts Road, Chelsfield, Orpington, Kent, BR6 7QL

T: 01959 533778 F: 01959 532544 E: sales@soundcraft-doors.co.uk www.soundcraft-doors.co.uk

Soundcraft is a trading name of JKR Services Ltd. Registered Office: Imperial House, North Street, Bromley, Kent BR1 1SD. Registered No: 2201723

