

# Hybrid series 1 composite sliding folding door system

Product Data Sheet  
Edition 02.2013  
Identification no. 000001  
Version no. 01

Page 1 of 2

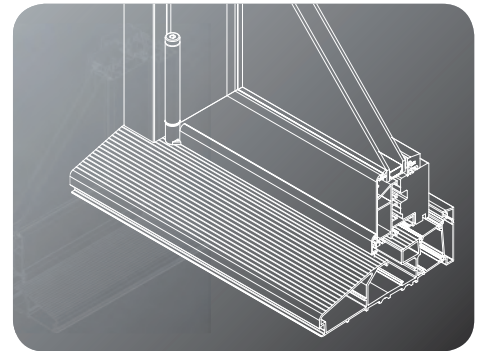

## Scope

Hybrid Sliding Folding doors have been designed to meet current and future building regulations, with impressive U values and thermal performances. Hybrid is a high insulation timber/aluminium composite system manufactured in the UK, complete with a selection of window, curtain walling and door options. It combines the long life and low maintenance of aluminium externally with the high insulation, environmentally focused benefits of responsibly sourced engineered timber internally. Glazing up to 36mm dependant on weight.

## Materials

- All aluminium sections are extruded using Aluminium Alloy 6060 or 6063 T6 to BS EN 755 part 9 2008.
- Polyamide thermal barriers are manufactured in accordance with PA66 GF25.
- Gaskets are manufactured in accordance with BS3734.
- Timber profiles are certified by MPA Stuttgart with quality class BS1100, laminated according to DIN1502 using weather proof and heat proof melamine glue; humidity 12% +/-2%; only lamellas without fault are laminated. Finger joints in outer layer min 500mm centres. PEFC /04-32-0042 certified. Timber profiles are matt lacquered 150-300 microns wet film thickness.

## Finishes

**Hybrid door sections are available typically in 4 finishes.**

- Polyester Powder Coating to BS EN 12206: 2004 Part 1 - painted in house. Surface finish at 40 microns standard, or enhanced to 60 microns for marine environments, in accordance with ISO9001, ISO14001 and ISO18001.
- Anodised and Anolok finishes are to BS3897: 1991 to a minimum of 25 microns (AA25), supplied in either satin or polished finish in a limited range of colours.
- Mill finish.
- Clear lacquered or painted timber

## Construction

Hybrid is constructed using mitred and mechanically crimped corners, with support chevrons and cleats and patented dovetail keys. Integral transoms and mullions are scribed around the outer frames and fixed with either screw ports or shear blocks. A proprietary sealant is used on all metal joints in line with good practice.

Timber mainframe sections are mitre jointed using a unique closed joint system. All cut faces are treated with the proprietary sealant, and all permanently exposed cut timber faces are sealed in accordance with the manufacturers recommendations. Opening leaves are designed to be inserted directly into the outer frames on butt hinges and rolling carriers.

Soundcraft, Orchard Building, Hewitts Road, Chelsfield, Orpington, Kent, BR6 7QL

T: 01959 533778 F: 01959 532544 E: sales@soundcraft-doors.co.uk [www.soundcraft-doors.co.uk](http://www.soundcraft-doors.co.uk)

Soundcraft is a trading name of JKR Services Ltd. Registered Office: Imperial House, North Street, Bromley, Kent BR1 1SD. Registered No: 2201723



  
**SOUNDCRAFT**  
DOORS & WINDOWS

# Hybrid series 1 composite sliding folding door system

## Environmental

Senior Architectural Systems is fully compliant with BS EN ISO 9001, BS EN ISO 14001 and OHSAS 18001 Standards. Hybrid when used on projects involved in a BREEAM assessment, or within the Code for a Sustainable Built Environment and the Code for Sustainable Homes (which therefore involves the Green Guide to specification) can offer significant benefits. For project specific assistance, please contact our specification team.

## Weather Rating

Differing door configurations produce different ratings. Please consult our technical department.

## Typical\* sizes

	Width (mm)		Height (mm)
Min Door	600	x	2020
Max Door	900	x	2284
Max Outer frame	6000	x	2400

\*For guidance only - when exceeded please consult our technical department.  
70kg max weight per leaf

## Glazing

Thickness	28mm	to	36mm
-----------	------	----	------

## Average U values

	2813mm (w) x 2400mm (h)
O/I 3 leaf	1.68W/m <sup>2</sup> K
O/O 3 leaf	1.62W/m <sup>2</sup> K

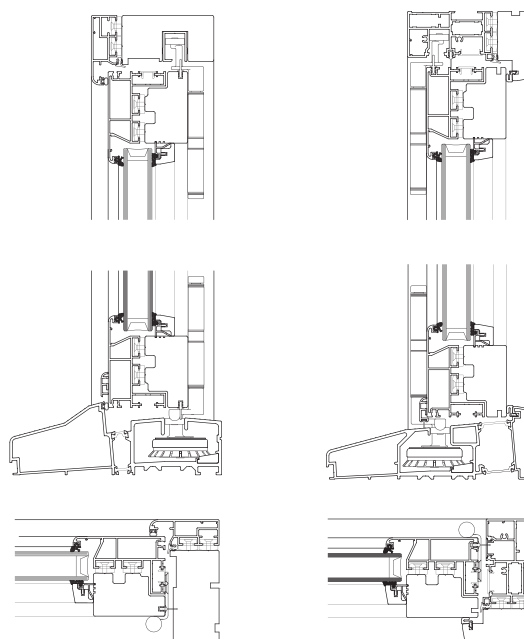

All data in this specification sheet is courtesy of Senior Architectural Systems. Soundcraft Doors and Windows works in partnership with Senior Architectural Systems.

**Soundcraft**, Orchard Building, Hewitts Road, Chelsfield, Orpington, Kent, BR6 7QL

T: 01959 533778 F: 01959 532544 E: sales@soundcraft-doors.co.uk [www.soundcraft-doors.co.uk](http://www.soundcraft-doors.co.uk)

Soundcraft is a trading name of JKR Services Ltd. Registered Office: Imperial House, North Street, Bromley, Kent BR1 1SD. Registered No: 2201723



# Hybrid series 1 composite entrance door system

Product Data Sheet  
Edition 02.2013  
Identification no. 000003  
Version no. 01

Page 1 of 2

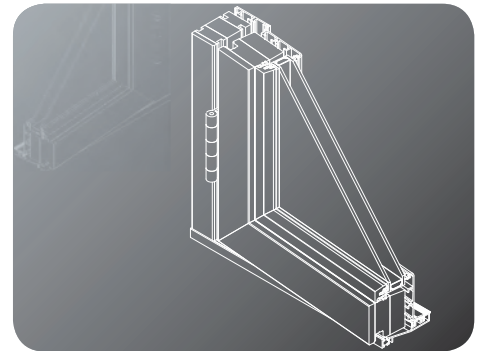

## Scope

Hybrid doors have been designed to meet current and future building regulations, with impressive U values and thermal performances. Hybrid is a high insulation timber/aluminium composite system manufactured in the UK, complete with a selection of window, curtain walling and door options. It combines the long life and low maintenance of aluminium externally with the high insulation, environmentally focused benefits of responsibly sourced engineered timber internally. Hybrid doors are available in single + double leaves, utilising low thresholds producing a variety of options. Glazing up to 32mm dependant on weight.

## Materials

- All aluminium sections are extruded using Aluminium Alloy 6060 or 6063 T6 to BS EN 755 part 9 2008.
- Polyamide thermal barriers are manufactured in accordance with PA66 GF25.
- Gaskets are manufactured in accordance with BS3734.
- Timber profiles are certified by MPA Stuttgart with quality class BS1100, laminated according to DIN1502 using weather proof and heat proof melamine glue; humidity 12% +/-2%; only lamellas without fault are laminated. Finger joints in outer layer min 500mm centres. PEFC /04-32-0042 certified. Timber profiles are matt lacquered 150-300 microns wet film thickness.

## Finishes

**Hybrid door sections are available typically in 4 finishes.**

- Polyester Powder Coating to BS EN 12206: 2004 Part 1 - painted in house. Surface finish at 40 microns standard, or enhanced to 60 microns for marine environments, in accordance with ISO9001, ISO14001 and ISO18001.
- Anodised and Anolok finishes are to BS3897: 1991 to a minimum of 25 microns (AA25), supplied in either satin or polished finish in a limited range of colours.
- Mill finish.
- Clear lacquered or painted timber

## Construction

Hybrid is constructed using mitred and mechanically crimped corners, with support chevrons and cleats and patented dovetail keys. Integral transoms and mullions are scribed around the outer frames and fixed with either screw ports or shear blocks. A proprietary sealant is used on all metal joints in line with good practice.

Timber mainframe sections are mitre jointed using a unique closed joint system. All cut faces are treated with the proprietary sealant, and all permanently exposed cut timber faces are sealed in accordance with the manufacturers recommendations. Transoms and mullions are installed by scribing the end then fixing to the outer frame. Opening leaves are designed to be inserted directly into the outer frames on butt hinges. Automation solutions are also available.

**Soundcraft**, Orchard Building, Hewitts Road, Chelsfield, Orpington, Kent, BR6 7QL

T: 01959 533778 F: 01959 532544 E: [sales@soundcraft-doors.co.uk](mailto:sales@soundcraft-doors.co.uk) [www.soundcraft-doors.co.uk](http://www.soundcraft-doors.co.uk)

Soundcraft is a trading name of JKR Services Ltd. Registered Office: Imperial House, North Street, Bromley, Kent BR1 1SD. Registered No: 2201723



  
**SOUNDCRAFT**  
DOORS & WINDOWS

# Hybrid series 1 composite entrance door system

## Environmental

Senior Architectural Systems is fully compliant with BS EN ISO19001, BS EN ISO 14001 and OHSAS 18001 Standards. Hybrid when used on projects involved in a BREEAM assessment, or within the Code for a Sustainable Built Environment and the Code for Sustainable Homes (which therefore involves the Green Guide to specification) can offer significant benefits. For project specific assistance, please contact our specification team.

## Weather Rating

Differing door configurations produce different ratings. Please consult our technical department.

## Typical\* sizes

	Width (mm)		Height (mm)
Single Door	900	x	1200
Double Door	1800	x	2100

\*For guidance only - when exceeded please consult our technical department.

## Glazing

Thickness	28mm	to	32mm
-----------	------	----	------

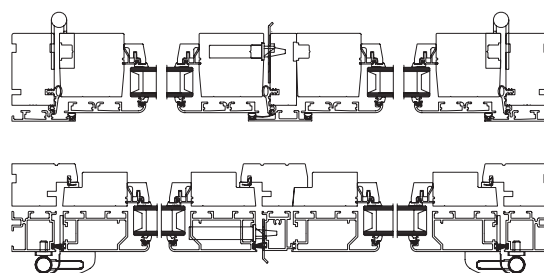

## Average U values

	Single	Double
O/I	1.35W/m2K	1.31W/m2K
O/O	1.51W/m2K	1.40W/m2K

## Security

O/O single door. Tested to PAS23/24, security hardware required

All data in this specification sheet is courtesy of Senior Architectural Systems. Soundcraft Doors and Windows works in partnership with Senior Architectural Systems.

Soundcraft, Orchard Building, Hewitts Road, Chelsfield, Orpington, Kent, BR6 7QL

T: 01959 533778 F: 01959 532544 E: sales@soundcraft-doors.co.uk [www.soundcraft-doors.co.uk](http://www.soundcraft-doors.co.uk)

Soundcraft is a trading name of JKR Services Ltd. Registered Office: Imperial House, North Street, Bromley, Kent BR1 1SD. Registered No: 2201723



# Hybrid series 1 composite lift/slide entrance door system

Product Data Sheet  
Edition 02.2013  
Identification no. 000002  
Version no. 01

Page 1 of 2

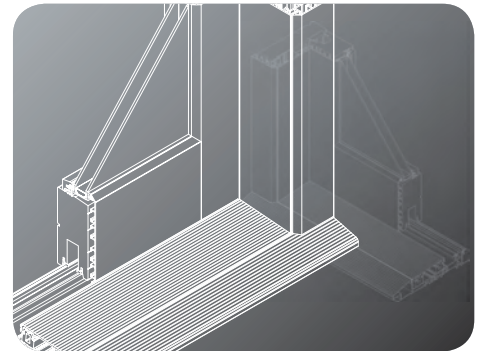

## Scope

Hybrid Lift and Slide doors have been designed to meet current and future building regulations, with impressive U values and thermal performances. Hybrid is a high insulation timber/aluminium composite system manufactured in the UK, complete with a selection of window, curtain walling and door options. It combines the long life and low maintenance of aluminium externally with the high insulation, environmentally focused benefits of responsibly sourced engineered timber internally. Glazing up to 36mm dependant on weight.

## Materials

- All aluminium sections are extruded using Aluminium Alloy 6060 or 6063 T6 to BS EN 755 part 9 2008.
- Polyamide thermal barriers are manufactured in accordance with PA66 GF25.
- Gaskets are manufactured in accordance with BS3734.
- Timber profiles are certified by MPA Stuttgart with quality class BS1100, laminated according to DIN1502 using weather proof and heat proof melamine glue; humidity 12% +/-2%; only lamellas without fault are laminated. Finger joints in outer layer min 500mm centres. PEFC /04-32-0042 certified. Timber profiles are matt lacquered 150-300 microns wet film thickness.

## Finishes

**Hybrid door sections are available typically in 4 finishes.**

- Polyester Powder Coating to BS EN 12206: 2004 Part 1 - painted in house. Surface finish at 40 microns standard, or enhanced to 60 microns for marine environments, in accordance with ISO9001, ISO14001 and ISO18001.
- Anodised and Anolok finishes are to BS3897: 1991 to a minimum of 25 microns (AA25), supplied in either satin or polished finish in a limited range of colours.
- Mill finish.
- Clear lacquered or painted timber

## Construction

Hybrid Lift & Slide Doors are constructed using straight cut joints secured with mechanical fixings. A proprietary sealant to protect against water entry should be used on all metal-to-metal joints at assembly. Timber mainframe sections are square cut using a unique mechanical jointing system.

Opening doors are design to be inserted directly into the outer frame and seated within the track system. Glazing is double glazing 28mm standard with an option for 32mm and 36mm.

**Soundcraft**, Orchard Building, Hewitts Road, Chelsfield, Orpington, Kent, BR6 7QL

T: 01959 533778 F: 01959 532544 E: [sales@soundcraft-doors.co.uk](mailto:sales@soundcraft-doors.co.uk) [www.soundcraft-doors.co.uk](http://www.soundcraft-doors.co.uk)

Soundcraft is a trading name of JKR Services Ltd. Registered Office: Imperial House, North Street, Bromley, Kent BR1 1SD. Registered No: 2201723



  
**SOUNDCRAFT**  
DOORS & WINDOWS

# Hybrid series 1 composite lift/slide entrance door system

## Environmental

Senior Architectural Systems is fully compliant with BS EN ISO 9001, BS EN ISO 14001 and OHSAS 18001 Standards. Hybrid when used on projects involved in a BREEAM assessment, or within the Code for a Sustainable Built Environment and the Code for Sustainable Homes (which therefore involves the Green Guide to specification) can offer significant benefits. For project specific assistance, please contact our specification team.

### Weather Rating

Differing door configurations produce different ratings. Please consult our technical department.

### Maximum\* sizes

	Width (mm)		Height (mm)
Outer frame	6000	x	2400

\*Weight limit up to 250kgs per leaf

\*For guidance only - when exceeded please consult our technical department.

### Glazing

Thickness	28mm	to	36mm
-----------	------	----	------

### Average U values

Two track (2.4m high x 2.4m wide)	1.45W/m2K
Three track (2.4m high x 3.6m wide)	1.51W/m2K

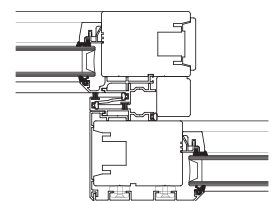
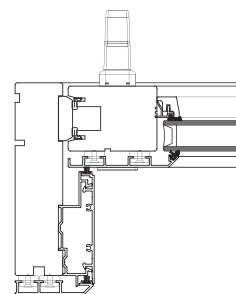
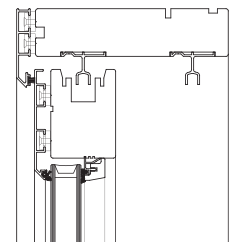
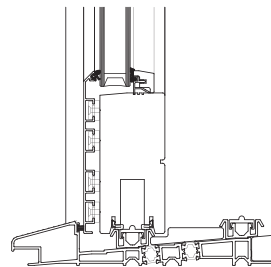

All data in this specification sheet is courtesy of Senior Architectural Systems. Soundcraft Doors and Windows works in partnership with Senior Architectural Systems.

Soundcraft, Orchard Building, Hewitts Road, Chelsfield, Orpington, Kent, BR6 7QL

T: 01959 533778 F: 01959 532544 E: sales@soundcraft-doors.co.uk [www.soundcraft-doors.co.uk](http://www.soundcraft-doors.co.uk)

Soundcraft is a trading name of JKR Services Ltd. Registered Office: Imperial House, North Street, Bromley, Kent BR1 1SD. Registered No: 2201723

